Detailed Design Review and Test Plan

FAMU-FSU College of Engineering
Department of Electrical & Computer Engineering
EEL4914/4915C

Team: #4 RoboSub

Team Members:

Dennis Boyd, Computer Engineering (dcb11c@my.fsu.edu)

Bjorn Campbell, Electrical Engineering (bec12@my.fsu.edu)

Samantha Cherbonneau, Computer Engineering (src11k@my.fsu.edu)

Kevin Matungwa, Computer Engineering (krm12d@my.fsu.edu)

Elliot Mudrick, Electrical & Computer Engineering (emm10k@my.fsu.edu)

Senior Design Project Instructor & Advisor: Dr. Mike Frank

Additional Reviewer: Dr. Victor DeBrunner

February 5, 2015

Project Executive Summary

The Association for Unmanned Vehicle Systems International (AUVSI) in conjunction with the U.S. Office of Naval Research host an annual competition in which teams from across the world develop autonomous underwater vehicles (AUVs), also called RoboSubs, that have certain abilities which are used to accomplish tasks within an obstacle course. AUVSI's primary goal of the competition is to "advance the development of Autonomous Underwater Vehicles (AUVs) by challenging a new generation of engineers to perform realistic missions in an underwater environment." It is the hope that the event not only helps to connect young engineers and the organizations developing AUV technologies, but also encourage excitement about STEM careers.

The competition is located in San Diego, CA at the TRANSDEC pool (pictured in Fig. 1) and typically takes place at the end of July or beginning of August. It lasts roughly one week, including several days of practice and two competition rounds. Performance during each round determines the progress of a team through the competition.



Figure 1: TRANSDEC Pool

In order to proceed with the competition, the sub must pass through a validation gate made of PVC pipe. After that, the following tasks are available for completion (based on the 2014 competition rules):

- Follow a path of orange line segments that guide the sub between tasks
- Bump a moored LED buoy that is alternating between Red and Green. Bump until buoy is stuck on green. Then bump a regular red buoy, followed by the regular green buoy.
- Maneuver around/over PVC by passing over the horizontal section, to the left or right of the center Red riser and inside the outer Green risers.
- Drop one marker in a bin with the primary alien target, and one marker in a bin with the secondary alien target.
- Fire a torpedo through a small hole in a target.
- Remove a red power pin that is a steel washer attached to a blue circle by a magnet, and then place the washer back in its original position.
- Capture one or more Mars rocks (red) or cheese blocks (green) and deliver them to the Sample box.
- Surface inside the proper PVC octagon based on which set of acoustic pingers are making sound.

This project would allow the team to develop a sub for the competition based on the work of teams in previous years and ideally compete this coming summer.

Table of Contents

Project Executive Summary.....	ii
1. Introduction.....	1
1.1 Acknowledgements.....	1
1.2 Problem Statement.....	1
General Problem Statement.....	1
General Solution Approach.....	1
1.3 Operating Environment.....	1
1.4 Intended Use and Intended User.....	2
1.5 Assumptions and Limitations.....	2
Assumptions.....	2
Limitations.....	2
1.6 Expected End Product and Other Deliverables.....	2
2. System Design.....	3
2.1 Overview of the System.....	3
2.2 Major Components of the System.....	3
2.2.2 Electrical Systems.....	4
2.2.3 Hull.....	4
2.2.4 Software Design.....	4
2.3 Subsystem Requirements.....	5
2.3.1 Main Processing Unit (MPU).....	5
2.3.2 Arduino UNO.....	6
2.3.3 Arduino Mega.....	6
2.3.4 Razor Inertial Measurement Unit.....	7
2.3.5 Motor Controllers.....	8
2.3.6 Camera System.....	8
2.3.7 Depth System.....	9
2.3.8 Vision System.....	9
2.3.9 Task Management System.....	9
2.3.10 Decision-making System.....	9
2.3.11 Movement System.....	10
2.3.12 Stabilization.....	10
2.4 Performance Assessment.....	10
2.4.1 Required Capabilities Assessment.....	10
2.4.2 Requirements.....	10
2.5 Design Process.....	11
2.6 Overall Risk Assessment.....	12
2.6.1 Technical Risks.....	12

2.6.1.1 Transportation of Sub	12
Description	12
Probability	12
Consequences	12
Strategy	13
2.6.1.2 Waterproof seal	13
Description	13
Probability	13
Consequences	13
Strategy	13
2.6.1.3 Plexiglas lid	13
Description	13
Probability	14
Consequences	14
Strategy	14
2.6.1.4 Error in system while in motion	14
Description	14
Probability	14
Consequences	14
Strategy	14
2.6.1.5 Lighting under water	15
Description	15
Probability	15
Consequences	15
Strategy	15
2.6.1.6 Burnout of components	15
Description	15
Probability	15
Consequences	15
Strategy	16
2.6.1.7 Universal battery life	16
Description	16
Probability	16
Consequences	16
Strategy	16
2.6.2 Schedule Risks	16
2.6.2.1 Pool Delays	17
Description	17
Probability	17
Consequences	17

Strategy	17
2.6.2.3 Not Enough Time Allocated to Tasks.....	17
Description	17
Probability.....	17
Consequences.....	17
Strategy	18
2.6.3 Budget Risks	18
2.6.3.1 Going Over Budget.....	18
Description	18
Probability.....	18
Consequences.....	18
Strategy	18
2.6.4 Summary of Risk Status.....	18
3. Design of Major Components/Subsystems	19
3.1 Overview.....	19
3.2 Component Interface.....	19
3.2.1 Wiring of Components to Each Other	19
3.2.2 Power System – Main Processing Unit.....	20
3.3 Software System	21
3.3.1 Task Management systems	21
3.3.2 Decision-making.....	22
3.3.3 Vision.....	22
3.3.4 Stabilization	23
3.3.5 Movement	23
4. Test Plan.....	25
4.1 System and Integration Test Plan	25
4.1.1 Power Systems.....	25
4.1.2 Depth Control.....	26
4.1.3 Obstacle Recognition and Movement.....	28
4.1.4 Overall Movement/Path.....	32
4.2 Test Plan for Major Components.....	33
4.2.1 Sub Hull	33
4.2.2 Depth Sensor.....	34
4.2.3 Obstacles	36
4.2.4 Killswitch.....	37
4.3 Summary of Test Plan Status.....	39
5. Schedule.....	40
6. Budget Estimate	42
7. Conclusion	43
8. References.....	44

1. Introduction

1.1 Acknowledgements

The RoboSub team members would like to thank Dr. Mike Frank for his general advisement throughout the project, as well as Dr. Victor DeBrunner for technical advisement. The team would also like to thank Dr. Nico Wienders for his help in finding an appropriate depth sensor for the sub, and also the FAMU-FSU College of Engineering for their financial contribution to this project.

1.2 Problem Statement

General Problem Statement

This summer AUVSI will host their 18th Annual RoboSub Competition in San Diego, CA. The competition is an obstacle course that requires an autonomous underwater vehicle to maneuver it. There are numerous tasks involved in the competition, and they all require the sub to have certain abilities in order to complete them. To complete some of the basic tasks, the sub must be able to:

- Run autonomously without any attachments
- Change depth, direction, and speed
- Pass through and around PVC structures
- Recognize colors

While these are not all the capabilities a sub would need to have in order to complete all tasks in the competition, they are the main capabilities that would result in a successful project for this team.

General Solution Approach

The sub is using the same hardware that was implemented in the last two year's design. For each task and subtask, the Logger function will output what the sub is currently doing by clever use of strings. This will allow for debugging based on whether the sub is doing the proper task at the proper time. The sub is completely battery powered. The code is written in C and C++.

1.3 Operating Environment

The primary operating environment of practice and testing of the sub throughout the year will take place in the FSU Morcom Aquatic Center, located in Tallahassee, FL. Since this pool is chlorinated, the buoyancy of the sub will be slightly higher than it would be at the competition pool. Additionally, the sub will have better visibility in the Morcom pool than in the competition pool.

The final operating environment will be the TRANSDEC pool in San Diego, CA. This pool is 300 ft by 200 ft by 38 ft and contains about 6 million gallons of saltwater, aiming to replicate ocean conditions. Because of the size of the pool, this facility is open-air and is exposed to all possible weather conditions. Within the facility, the sub will be transported by a crane and will be placed in a sling to be inserted into the water for testing and competition.

1.4 Intended Use and Intended User

The intended use of this sub is to compete in the AUVSI RoboSub competition in San Diego, CA in summer 2015. It will complete the validation tasks, such as passing through the validation gate, and also perform a number of other tasks throughout the course.

The team members of this project are the only intended users, as they will be the only operators of the sub. Future project team members are also considered to be intended users, yet they are not going to be using the sub this year.

1.5 Assumptions and Limitations

Assumptions

- The rules for the 2015 competition will be very similar to the 2014 competition. Since the rules and requirements have not yet been posted, the team is to work on the project as though it is being prepared for last year's competition.
- The visibility conditions will not largely differ between the practice pool and the TRANSDEC pool.
- The sub will not behave differently at 17 ft (depth of Morcom pool) versus 38 ft (depth of TRANSDEC pool).

Limitations

- The body of the sub must be reused from last year as there is not enough money to redesign it, nor are there any mechanical engineering students on the team to assist in a redesign.
- The sub can weigh no more than 125 lbs and must fit in a space that is 6 ft by 3 ft by 3 ft, according to the requirements from last year's competition.
- The financial budget is not large as most of the work expected to be performed is programming.
- Testing facilities on campus are not capable of replicating ocean conditions.

1.6 Expected End Product and Other Deliverables

The completion of this project shall result in the creation of a fully functional autonomous underwater vehicle (AUV), also referred to as a "sub". It is expected that this sub will qualify for the AUVSI RoboSub competition in California and compete in the summer of 2015.

In addition to the completed sub, the team is to produce a website, journal paper, and introductory video for the competition. It is expected that the website will contain all team information and work, and the journal paper will be a technical paper which contains the operations and functionality of the sub, essentially a user manual. The purpose of the video is to introduce team members and their sub to the AUVSI committee and all others involved.

2. System Design

2.1 Overview of the System

The following section will discuss the major components, subsystems, and software of the AUV's design, and how it will all work together to complete the competition's tasks. The design of the AUV will build off of last year's previous year's design. The major goal of this year's team is to complete software portions of the project. This allows the AUV to compete in the AUVSI competition.

2.2 Major Components of the System

Each controller, sensor, actuator, and thruster uses a specific voltage and current. Due to the differences in the voltages and currents there are separate batteries being used for the different components. Fully charged, the batteries power the AUV will last the twenty minutes that are allowed to complete the competition. The below tables list the power requirements of the components.

Table 1: Power Supplies

Power Supply	Voltage (V)	Max Voltage (V)	Cut Off (V)	Max Discharge Current (A)	Capacity
Lithium Ion Battery Pack	14.8	16.8	11.0	30.0	20 Ah or 296 Wh
Universal Laptop Battery	16 or 19	19.0	13.0	3.0	4000 mAh

Table 2: Component Requirements

Components	Max Current (A)	Ave. Current (A)	Voltage Required (V)
Zotac PC Board	3.5	1.5	19.0
Arduino UNO	0.75	0.5	7.0 - 12.0
Arduino Mega	0.75	0.5	7.0 - 12.0
Motor Controllers	2.0	1.5	5.0
IMU	0.075	0.060	3.5 - 16.0
Thrusters	12.0	3.0	19.1
Depth Sensor	0.020	0.012	8.0 - 11.0

2.2.2 Electrical Systems

The electrical system consists of last years design. The hardware required to control the AUV is comprised of a main controller and subsystems of self-sustaining electrical components. The microcontrollers used in this AUV are an Arduino Uno and a Arduino Mega. The Arduino's do not always need outside assistance when running. This will take some of the processing power off of the main CPU.

2.2.3 Hull

The main aspect of the hull is waterproof the electronics. Last year's team hull design will be used. The hull is interchangeable with respect to the outer electronics placements, this includes the thrusters, webcam, torpedoes tubs, and depth sensor. A CAD model of last year's final design is shown below.

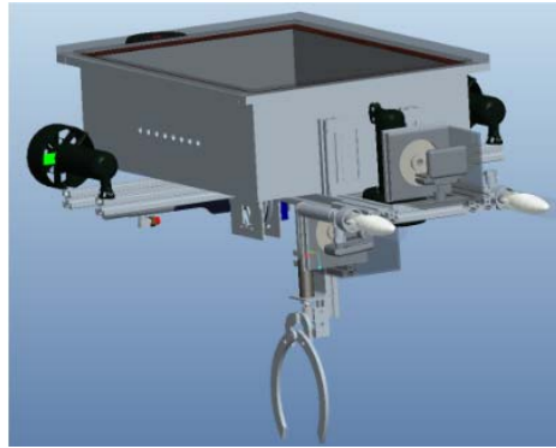

Figure 2: CAD Model of Sub Hull

Source: RoboSub_Project_Proposal_2012. FSU RoboSub, 2012, PDF

2.2.4 Software Design

The block diagram below shows the high-level design of the sub's programming. Primary hardware pieces are also included to provide a clear understanding of the functional hierarchy. Threading was used to create a high level of parallelism, most evident in the four independent lines coming from the main routine (RoboSubControl_v2), and the cluster of processes spawning from Gate. The Task Manager and DMCS (Decision-making Control System) interface through the missionTasks stack, and control what task is activated. Since the complicated thruster interface is detailed in 3.2, a single "Thrusters" block is included in this diagram to simply show the general flow of data. Most of the blocks represent completed existing code (although image processing through the Database is incomplete), but the red blocks represent intended new code. These are the primary tasks this project will be tackling.

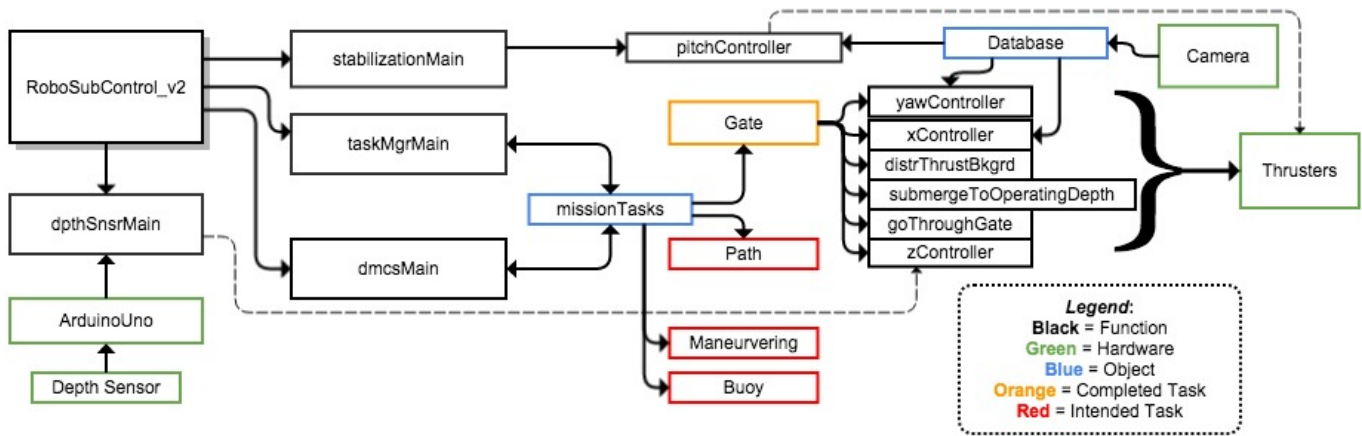

Figure 3: Software Flow

2.3 Subsystem Requirements

2.3.1 Main Processing Unit (MPU)



Figure 4: Zotac Computer

The Zotac computer will act as the main processing unit for the AUV. Being the MPU, the Zotac is essentially the sub's "brain" and will be responsible for most of the high-level communication. The Zotac will also be home to an extensive software library that will encourage the autonomous nature of the sub by allowing it to make decisions based on inputs from the different peripherals connected to the MPU.

The MPU will interface with one Arduino Mega and an Arduino UNO microcontrollers. Making use of the USB ports to establish bidirectional UART serial communication links with the Arduino microcontrollers, information will be sent to the Arduinos to control various hardware such as the thrusters, and depth sensor. Going in the other direction, the microcontrollers will regularly update the MPU with necessary mapping and control data such as current latitude readings and acceleration readings as well as relative depth readings. The serial communication links will be opened at a baud rate of 19,200 bits/s and zero parity. The Zotac computer will also utilize two Logitech webcams connected via USB for vision information.

The MPU will receive power from an external 19V universal laptop battery. Additionally, the MPU will act as a power source, utilizing five of the six available USB ports to power the Arduinos and cameras.

2.3.2 Arduino UNO

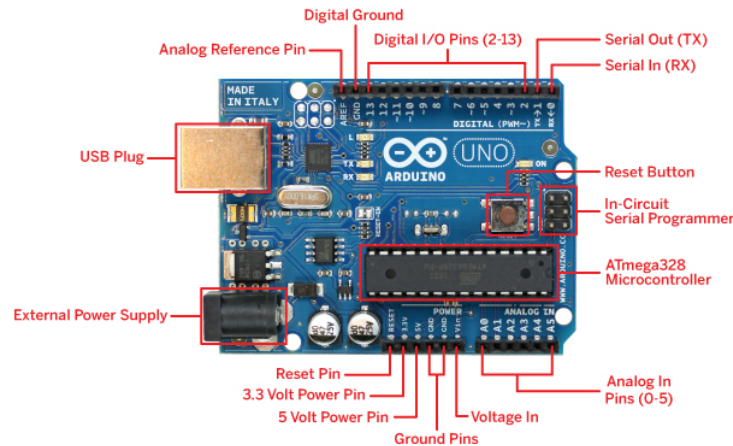

Figure 5: Arduino Uno

The Arduino UNO will act as the main microcontroller for the Depth Sensor. The microcontroller will interface with the MPU via a UART serial communication link channeled through the USB port. As mentioned in the previous section, the serial communication link will have a baud rate of 19,200 bit/s to ensure data is transmitted quickly yet effectively. A higher baud rate can be handled by the Zotac computer but leads to possible transmission errors when data is being sent from the Arduino.

The Arduino UNOs will receive power from the USB connection to the MPU. The microcontroller will be supplied with 12 V. The Arduino Uno will then read an analog voltage output for the depth sensor (Levelgag).

2.3.3 Arduino Mega

The Arduino Mega microcontroller is the main hub related to controlling and communicating with the motion control hardware. This microcontroller will thus be responsible for interfacing with the motor controllers that control the thrusters and with the main processing unit.

The Arduino Mega microcontroller will communicate with the Zotac computer through a UART serial link, which is channeled through the USB ports of both devices. The serial communication link sport an effective baud rate of 19200 bit/s to ensure data is transmitted quickly yet effectively. As mentioned in the previous section, a higher baud rate can be handled by the Zotac computer but leads to possible transmission errors when data is being sent from the Arduino.

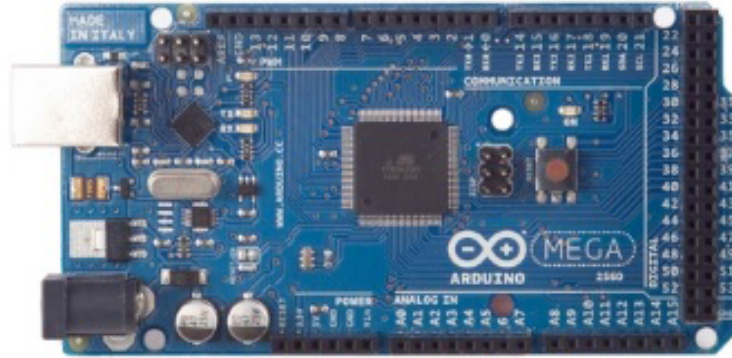

Figure 6: Arduino MEGA

As shown in the figure above, four motor controllers will be connected to the Mega. Two of the motor controllers will supply voltage to two thrusters each. These motor controllers will therefore require the use of six pins on the Mega, two of which must be analog (PWM) pins in order to have variable control of the speed the thruster propellers are rotating. The other two motor controllers will supply voltage to one thruster each. These devices will therefore require three pins each, one of which must be an analog (PWM) pin in order to have variable control of the thrusters.

The Arduino Mega will receive power from the MPU through the USB connection. Each of the four motor controllers will be supplied with 14.8V as input from the thruster and motor controller power system.

2.3.4 Razor Inertial Measurement Unit

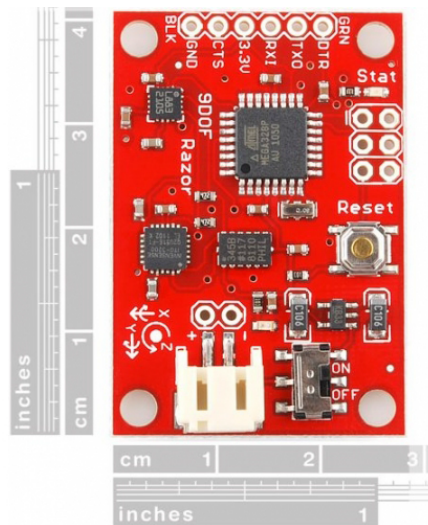

Figure 7: IMU

The Sparkfun Razor IMU is a sensor that will be used to determine current acceleration data, which will be valuable in describing the AUV's current state of balance.

The IMU will directly interface with the Zotac PC via the FTDI Breakout Board, which acts as a serial communication link. The RazorIMU is therefore supplied with the ideal voltage and current flow to operate by connecting the 3.3V and GND pins from the Breakout Board to the respective 3.3V and GND pins on the IMU.

2.3.5 Motor Controllers

The chosen motor controller is late years L298 H-Bridge. Last year's motor controllers will be used to reduce costs. Research on the boards was done to assure that they work well with the current design and can interpret PWM signals from an Arduino microcontroller. There are two brands of the L298 H-Bridge motor controller that will be used in the AUV. The first is the CanaKit driver, the second Solarbotics driver. Both motor controllers are very similar in specifications. And thusly, will perform the same functions. The motor controllers will determine the voltage to apply to each thruster. The motor controllers will get this information from the Arduino Mega. Each motor controller requires 5 V from the Arduino Mega, and can supply the thrusters with up to 2 amps current.

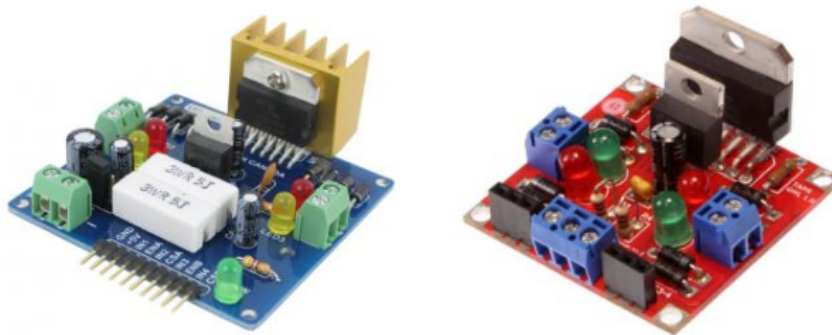

Figure 8: Motor Controllers

The motor controller on the left is the CanaKit driver and the Solarbotics driver is on the right.

2.3.6 Camera System

The vision system will use two C615 webcams. One webcam will be positioned horizontally in the front of the AUV. The other webcam will be placed on the underside of the AUV. The horizontal webcam will function with detecting the Gate and maneuvering the structure. The bottom webcam will detect the path segments on the floor of the pool. The webcams from last year and will be used this year. Additionally, each webcam is powered by USB so no external power adapter will be necessary.

2.3.7 Depth System



Figure 9: Depth Sensor

A new depth sensor has been installed for the AUV. A General Purpose Submersible Level Transmitter (Levelgage) was ordered and installed on the sub. The Levelgage provides an analog voltage output to the Arduino Uno. The voltage output varies from 0-5V. The levelgage is accurate to 1% depth. The Arduino Uno then sends the data to the Zotac for processing.

2.3.8 Vision System

This subsystem will analyze the data from the cameras and output the findings to other subsystems. Part of this system is the SLAM gives outputs that include the angle and distance to the next target. This system will therefore identify shapes and colors along the course and determine their location. In order to achieve the flexibility of identifying different course objectives, the vision system will be supplied with images to compare each object. Then determine if they are a competition structure, such as finding a path instead of a gate.

The vision system is the software module that satisfies all of the necessary image processing needs of the AUV. Modules from this system will be called when needed by the top-level control software. Written using OpenCV and Castle's SLAM, this module will implement object recognition, a frequently occurring problem in the contest. The vision system will supply the task manager and decision maker with a map to complete the tasks.

2.3.9 Task Management System

The task management system will have a list of the tasks for the competition. It controls the order in which the task is completed and will perform the overall task management of the sub. Using the information provided to the task management system from the sensors, the system can number and order the states to satisfy the tasks.

2.3.10 Decision-making System

The objective for the decision-making control system will be to plan the goal of the AUV. As each task command is completed the decision maker will update the status to determine what the next command would be. The decision-making process will be a thread and thus will always be running, until the sub has completed all the tasks.

The DMCS should have the final say on the completed status of the current task, and on whether a task should be paused and continued later if it cannot be completed at this time.

2.3.11 Movement System

The thrusters are told what to do through the motor controllers, wired to the Arduino MEGA, which communicates via USB with the Zotac. Pulse-Width Modulation is used to control the thrusters. Two of the motor controllers are bridged, which is accounted for in the main code on the Zotac. This allows these to supply greater power to the thrusters. Which thruster is activated then controls the sub's movement, as can be seen in detail in Figure 12.

2.3.12 Stabilization

The AUV stabilization control system will receive data from the inertial measurement unit's data-acquisition subsystem, process that data, and send the appropriate parameters to the motion control unit to balance the AUV in the water. This process effectively stabilizes the AUV at all times.

2.4 Performance Assessment

All requirements of the AUV were identified in the Needs Analysis and Requirements Specifications. This section will detail the design decisions made in order to satisfy each requirement and capability

2.4.1 Required Capabilities Assessment

- CAP-001: Run autonomously
- CAP-002: Pass through the validation gate
- CAP-003: Follow a path of orange line segments that guide the sub between tasks

The remaining part of the course are wants that will allow the project team and RoboSub to be competitive.

- CAP-004: Bump a moored LED buoy that is alternating between Red and Green. Bump until buoy is stuck on green. Then bump a regular red buoy, followed by the regular green buoy.
- CAP-005: Maneuver around/over PVC by passing over the horizontal section, to the left or right of the center Red riser and inside the outer Green risers.

2.4.2 Requirements

The following requirements list the technical specifications required by the AUVERSI Foundation. These are the specification for the vehicles tasks that need completion.

- REQF-0001: Path Following. Consists of following line segments (6 inches wide) from the Gate to Control Panel, to the Maneuvering area, past the Landing Site, and finally to the landing zone.
 - Path component construction scheduled for January. Path recognition and following being designed.

- REQF-0002: Control Panel (Buoy). Three buoys of different colors need to be bumped. Depending on the buoy color different amount of bumps are required.
 - Buoy construction and programming will happen in the spring when current rules are posted.
- REQF-0003: Maneuvering: The AUV will have to maneuver around a PVC with three risers. Two different paths can be chosen what given points.
 - Construction of Maneuvering platform and maneuvering programming will happen in the spring.
- REQF-0004: Landing Site (Bins). Four bins will be used arranged in a square. The AUV can carry 2 markers to drop into the bins.
 - Requirement deleted.
- REQF-0005: Brunch (Torpedoes firing). The AUV can fire two torpedoes at small circular cutouts.
 - Requirement deleted.
- REQF-0006: Reroute Power. Remove a steel washer connected to a red power pin and place on an unoccupied blue circle.
 - Requirement deleted.
- REQF-0007: Recovery Area. Remove mars rocks/cheese from the recovery area and place them in the Sample Box.
 - Requirement deleted.
- REQF-0008: Interference. The AUV will not interfere with course components otherwise disqualification can occur.
 - Requirement will be met when testing with a kill switch and diver with the AUV.
- REQF-0009: The pingers that we will use will be Teledyne Benthos ALP-365 pingers. They can be set from 25-40 kHz in 0.5 kHz increments.
 - Requirement deleted.

2.5 Design Process

The system design for this group was physically minimal. The design of the hull, and the sub in general will not be changed from last year. Very few components will change either. The most significant change is that some have been removed. Specifically the torpedo launchers, claw, and hydrophone have been removed as these tasks seem unlikely to be accomplishable. Of course, if there ends up being enough time to complete more tasks, these components may be added back on, but will still remain unchanged from last year.

The only major design change will be the integration of the new depth sensor. As it is a different brand (Keller Levelgage; last year's was a Honeywell TruStability), it may provide different values than last year's sensor (although both output an analog voltage from 0-5V). Thus the code translating the sensor's output to a usable value may need to be changed. The Levelgage sensor also requires more power than last year's Honeywell: 8-11Vdc versus 3.3-5Vdc. Thus the power

system in place will likely need to be modified to accommodate this increased power need. An extra battery is installable in the sub, as it had been used previously. So, that is there if needed.

This year, the design will focus on path following, completing the buoy task, and completing the maneuverability task. This will be accomplished by building upon the existing code.

Specifically, the code used for color recognition and object tracking from last year will be modified and applied to new tasks, beyond just passing through the validation gate. Furthermore, the task manager and decision maker, rather than being rewritten, will be amended to include the new tasks. The programming of these tasks constitutes the majority of the work for this project.

2.6 Overall Risk Assessment

Overall Risk Assessment

2.6.1 Technical Risks

There are many technical risks associated with this project and all of them can occur at any point during the project. None of the risks described below have happened at this time, but that is not to say that they will not occur. A few of the risks could result in catastrophic consequences, meaning that they would prohibit continuation of the project.

2.6.1.1 Transportation of Sub

Description

Transportation of the sub is where the most damage is likely to occur, since the majority of testing will require transporting the sub to the Morcom Aquatic Center. This is due to the terrain that the transportation cart must be pushed along. If the surface is not completely smooth (i.e. pavement) then it causes a large amount of vibrations, which cause the entire cart, sub included, to shake vigorously. It is this type of movement that could result in loosening of parts and cause parts of the sub to fall off and/or break.

Probability

MODERATE

If the sub were to be damaged during transportation, there would be a large impact on the project because any damage to the sub would cause a delay in the project.

Consequences

MODERATE/SEVERE

Depending on the severity of the damage, the severity of the consequences can change. If a piece of the thruster were to break off, it is fairly easily replaceable. However, if the sub were to fall to the ground and the body of it break, that would be a severe consequence as we may not then be able to complete the project in a timely manner because of the delay that would result.

Strategy

Move the cart slowly and in a careful manner, so as to limit the amount of severe vibrations. When transporting the sub via automobile, drive safely and cautiously. Potentially look into shock-absorbing wheels if the vibrations become a large issue. A towel has also been added to the cart for the sub to sit on so that it will absorb a large portion of the shock.

2.6.1.2 Waterproof seal

Description

At any point the waterproof seal surrounding the sub could wear to the point of becoming no longer effective. If this is not addressed before submerging the sub in the water, it could lead to the destruction of the electronics enclosed within the sub.

Probability

MODERATE/HIGH

The age of the seal, as well as the manner in which it was created make the probability of this risk moderate to high.

Consequences

CATASTROPHIC

If the waterproof seal were to fail during water testing, the results could be catastrophic because the water could permanently damage the electronics and thus make it impossible to complete the project.

Strategy

Be vigilant about checking the waterproofness of the seal. Check the functionality of the seal prior to testing the sub with the electronics inside. If the seal is no longer waterproof, this quick test would make the team aware of the faulty seal and would not risk damaging the electronics.

2.6.1.3 Plexiglas lid

Description

There are currently small cracks in the Plexiglas lid of the sub, which could be exacerbated with increased depth and pressure. As the team only has access to a 17 ft deep pool and the competition pool is 38 ft deep, it will not be known until competition time if the increased depth will increase the pressure enough to cause the small cracks to weaken. If the cracks weaken enough, it could result in large cracks that allow water into the sub, thereby no longer making it waterproof. In order to have a good enough seal around the lid, the bolts must be incredibly tight. Tightening the bolts too much could also result in the small cracks becoming larger.

Probability

LOW

It is unlikely that the lid will fail during our testing at the Morcom pool, but it is a possibility that it may fail at the competition as we do not have a pool deep enough to test using competition settings.

Consequences

CATASTROPHIC

If the lid were to crack/break while under water, the water could leak into the sub and cause damage to the electronics inside. This would result in the sub being unusable.

Strategy

Be very careful when tightening the bolts on the lid and do not tighten them past the appropriate point. Additionally, keep a close watch on the small cracks in the lid to ensure that they do not become large enough that they would be susceptible to breaking under a large pressure increase.

2.6.1.4 Error in system while in motion

Description

An error could result in the navigation system while testing in the pool, and this could result in the sub suddenly changing direction and colliding with a pool wall and/or other obstacle.

Probability

MODERATE

This is a risk that could occur depending on the quality of code and testing that was performed before testing underwater.

Consequences

MINOR/MODERATE

Should this occur, it would result in more time being devoted to fixing the errors which could delay the project for a small amount of time. The sub most likely will not be moving at a speed fast enough to do much damage to the sub if it were to collide with something. The portions of the sub that would be most likely to experience damage if a collision were to occur would be the cameras and thrusters.

Strategy

Have at least one team member in the water with the sub at all times, along with a functioning kill switch that can be accessed at any time to completely stop the sub.

2.6.1.5 Lighting under water

Description

The TRANSDEC pool is made to mimic ocean conditions with less visibility than the Morcom Pool. At greater depths visibility could become even worse. This could result in the sub being unable to navigate properly or complete tasks in the course.

Probability

LOW

It is likely that the water will have a different visibility than the Morcom pool will. However, after viewing videos of the most recent competition, the visibility appears to be very high and likely will not pose a threat to the operation of the sub.

Consequences

MODERATE

If the sub cannot detect the colors properly, it may not be able to complete tasks in the course or navigate accurately.

Strategy

Attach a small light to the camera (pointing in the same direction as the camera), which would always supply the same amount of light to what the camera is reading. This would increase visibility and make the readings of the camera more reliable. Another viable option would be to perform a “white-out” on the system beforehand. This would require using a baseline white object as the base for the color values, thus when it is calibrated under water, the color values will be accurate.

2.6.1.6 Burnout of components

Description

Any any point the thrusters and/or electric boards could burn out due to overuse or overheating. This could cause them to become unusable.

Probability

LOW

Even though some of the components are a few years old, this is fairly unlikely to occur as the components have not been used all that frequently.

Consequences

MODERATE

If the components were to burn out or break, we would need to replace that component which would be possible but would result in a minor delay.

Strategy

Ensure that the sub is not overheating and all wiring is properly done. If such a burnout does occur, the team shall be prepared to quickly order a replacement part.

2.6.1.7 Universal battery life

Description

The output connection is slightly damaged and any sudden movement could sever the connection, resulting in a loss of power to the sub. The current life of a full charge is very limited, which decreases the amount of time of a testing session.

Probability

HIGH

The probability of the universal battery failing at some point is high because of its age and how it is currently operating.

Consequences

MINOR

If the battery were to fail during testing, the sub would need to be immediately retrieved from the pool because it no longer can operate properly without power. At this point, a spare battery could be used and no delay would result.

Strategy

Order another rechargeable battery that can hold a charge longer. The current one can be used as a backup should something happen to the new battery. This new battery will allow for more reliable testing and functioning of the sub.

2.6.2 Schedule Risks

Scheduling conflicts can arise from outside sources as well as internal conflicts. Since the primary testing facility is outdoors, weather is a factor with respect to time constraints. Additionally, the facility has many other events and will not always be available for testing purposes. Finally, tasks may not have accurate or realistic amounts of time allocated to them.

2.6.2.1 Pool Delays

Description

Relying on an outdoor University facility to test the sub could result in delays due to weather or scheduling conflicts because of University-sponsored events being hosted at the pool. This could potentially delay testing of the sub which could delay the entire project.

Probability

MODERATE

As the weather is not very predictable, this could impact the testing schedule and result in possible delays.

Consequences

MODERATE

Depending on how much of a delay has been caused, the impact on the sub would most likely only be moderate and would be quite manageable.

Strategy

Be aware of prior reservations at the pool and schedule testing around those dates. Also, identify more than one day/time of possible testing so if there is a delay due to weather, the alternative day/time can be used without a significant delay.

2.6.2.3 Not Enough Time Allocated to Tasks

Description

There is potential for tasks having insufficient time allocated to them.

Probability

HIGH

The schedule was designed as a guideline for completing tasks. For this reason, some tasks will probably take longer than anticipated to complete. Additionally, some tasks may take less time than anticipated but the latter is less likely.

Consequences

SEVERE

If a task has drastically less time allocated to it than what is actually required, it could lead to the team not completing the project (worst case). A less severe result could be that some tasks may be dropped.

Strategy

The schedule is designed so that one task is completed before then next one begins. This means that if one task takes significantly longer to implement than expected, then later tasks can be omitted without wasting any time trying to partially implement them.

2.6.3 Budget Risks

The primary risk associated with the budget is spending more money than the school as supplied the team with for the project. It is crucial that no more money is spent than the team has been allocated.

2.6.3.1 Going Over Budget

Description

As with any project that requires financial assistance, there is always the risk of going over the allotted budget in order to purchase the necessary supplies.

Probability

LOW

Apart from the depth sensor and new battery, all costs associated with completing this project are fairly low and thus put the team at a low risk for going over-budget.

Consequences

SEVERE

Should expensive components break that were not anticipated, it could result in the team going over-budget. If the team goes over the allotted budget then there is no longer any funding from the school and thus all costs are out-of-pocket.

Strategy

Closely monitor and manage the budget and all costs associated with the project. If the team is getting close to spending all allotted money, then costs will be analyzed even more to determine how necessary they are to the completion of the project.

2.6.4 Summary of Risk Status

The risks detailed above range in both probability and severity of consequences, yet all are being well managed. The proper testing will be performed to avoid failures of systems, and all systems and components involved are being closely monitored to ensure that if one of the above risks is to occur, it will be noticed quickly and the team will go into action to subvert possible consequences. Some of the risks are out of control of the team, such as weather delays and the publication date of the official competition rules, but the team is equipped to manage those risks should they occur. At this time, project financial expenditures have been fairly low, with the

exception of the depth sensor and battery. The team treasurer has the budget under control at this time, and thus no additional assistance is required.

3. Design of Major Components/Subsystems

3.1 Overview

Since the RoboSub has already been constructed, the physical design is already complete. Furthermore, the interface design between the components is unlikely to change very much. Although, since the rules for this year will be different than last year's, some redesign may be necessary. The primary goal of this project, however, is to improve upon the existing code to allow the RoboSub to complete more tasks at the competition. Thus the flow of the sub's code is the most pertinent to understanding of this project.

3.2 Component Interface

3.2.1 Wiring of Components to Each Other

The block diagram below details the connections of the primary hardware components. There are two microcontrollers used to interface with the CPU and control the sensors and motor controllers (L298 MC). An Arduino UNO interfaces with the depth sensor, while the Arduino MEGA constitutes the primary control, interfacing with the smaller controllers for the thrusters and the IMU (Inertial Measurement Unit). The cameras interface directly with the CPU (through the database and subroutines seen below).

The more detailed wiring of the thrusters with the MEGA is shown in Figure 11. Four motor-controllers are used to interface between the MEGA and the thrusters.

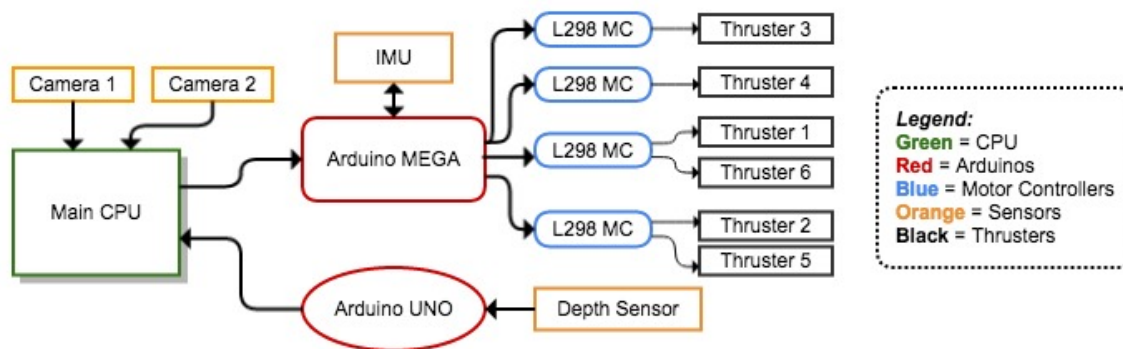

Figure 10: Hardware Overview

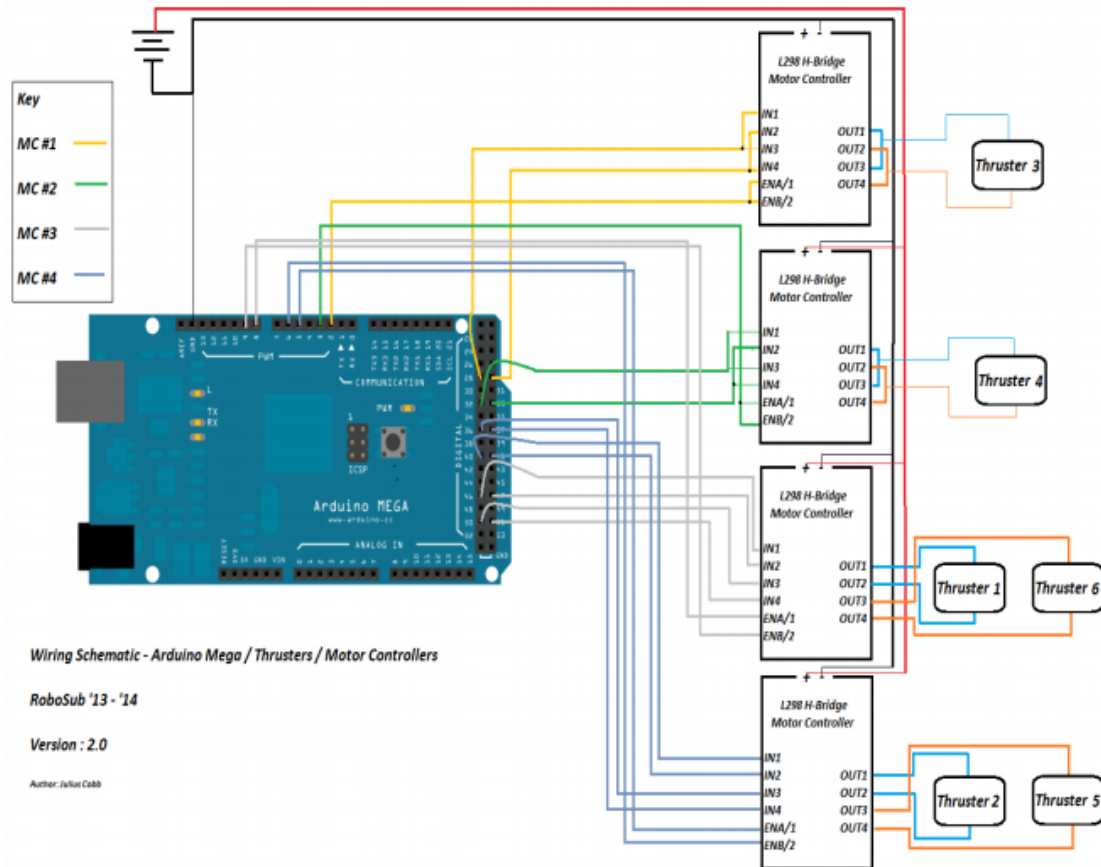

Figure 11: Connections of Arduino MEGA, Motor Controllers, and Thrusters

Source: *Autonomous RoboSub 2013-14 Final Report*

3.2.2 Power System – Main Processing Unit

The first power supply unit will power the Zotac computer, which acts as our main processing unit. The battery that was chosen to power the MPU is a 19V lithium-ion universal external battery. This particular device, though large in capacity, is compact in size and does not weigh much. The minimal size and weight will thus decrease the amount of space the battery takes up when placed inside the electronics housing as well as help minimize the total weight.



Figure 12: Zotac Battery

- Capacity: 4000mAh
- Running time: 23 hrs. dependent on model of PC
- Output: 19V DC
- Max. Discharging: 3A
- Dimension: 155x100x23 mm
- Weight: 2.8 lbs (1270g)

As the specifications show, the battery will supply power to the MPU for more than enough time. Consistent and reliable power to the MPU is important because not only is the MPU the brain of the AUV, but it will also act as an intermediate power supply for a few peripheral devices including two Logitech HD video cameras, the Arduino Mega and the Arduino Uno microcontroller. The aforementioned devices will thus take advantage of the six different USB ports on the MPU to receive adequate power for operation.

3.3 Software System

3.3.1 Task Management systems

The tasks shall be approached using a stack. The task management system is tightly coupled with the decision-making system. Each task will have a set of commands. As the commands are executed, the task status will be updated. Once the status reaches complete, the current task shall be popped off of the stack. The pseudocode for the commands associated with the Gate is provided below.

```
void TaskMrgMain()
{
    while(true)
    {
        if(missionTasks.empty())
            break;
        else if (missionTasks.top()-> getTaskName == "TASKNAME")
        {
            missionTasks.top()->gateCmds.pop();
            pthread_cond_signal(&taskIdentified);
            while (!missionTasks.top()->gateCmds.empty())
            {
                pthread_mutex_lock(&nextCommandWait);
                pthread_cond_wait(&cmdComplete, &nextCommandWait);
                missionTasks.top()->gateCmds.pop();
                pthread_mutex_unlock(&nextCommandWait);
            }
        } //all task have been completed
    } //end taskManager loop
} //end TaskMrgMain
```

3.3.2 Decision-making

The decision-making control system is a state machine where each state corresponds to a task command at the top to the stack. The state machine will be embedded in a loop that checks to make sure the status of the task is incomplete and also making sure that the task has not been aborted. The decision-making heavily works with the task management. Therefore once the decision maker has gone through a set of commands in a particular task, the task stack will be checked to make sure it is not empty before attempting to cycle through the decision-making loop once again. The pseudocode for the decision-making code is shown below.

```
while(!missionTasks.empty())
{
    if(missionTasks.top()->getTaskName() == "TASKNAME")
    {
        submergeToOperatingDepth();

        myTask.setState(Types::TASK_STATE::IN_PROGRESS);

        while(myTask.getState() != Types::TASK_STATE::COMPLETED
            && myTask.getState() !=Types::TASK_STATE::ABORTED)
        {
            switch(missionTasks.top()->TaskCmds.top())
            {
                case Types::TASK_COMMANDS::COMMAND_1:
                {
                    do something //adjust thrusters
                    pthread_cond_signal(&cmdComplete);
                    break;
                }
                default:
                break;
            } // end Task command case statements
        } // all Task commands are completed
    } // end DMCS gate section
} // all Mission Tasks are done
```

3.3.3 Vision

The RoboSub is equipped with two cameras, used for color recognition and object tracking. This is done using SLAM (Simultaneous Localization and Mapping) and the OpenCV library. OpenCV is used for SURF (Speed-Up Robust Features) and for color recognition. These things have already been written, but will be implemented for tasks other than passing through the validation gate. Some of the code can be found in Appendix A 3.3.6 and 3.3.7 of last year's team's *Autonomous RoboSub 2013-14 Final Report*.

3.3.4 Stabilization

An Inertial Measurement Unit onboard is used to correct the roll and pitch to keep the sub stable while in motion. The Razor AHRS Sparkfun IMU open source library is utilized to get the reading of the sub's orientation. The pseudocode for the positive overshoot pitch correction is provided below.

```
void* pitchController(void* arg)
{
    while(!Stopped)
    {
        measuredValue = myIMU->getPitch();
        error = setpoint - measuredValue;
        if(error > 4.0f)
        {
            pthread_mutex_lock(&heaveMutex);
            initialThrust = dataBuf[0];
            prevError = error + 0.2f;
            do
            {
                derivative = (error - prevError) / delayTime;
                prevError = error;
                output = kP * error + kD * derivative;
                tmp = convertPitchCtrlOutput(output, true);
                dataBuf[0] = initialThrust + tmp;
                measuredValue = myIMU->getPitch();
                error = setpoint - measuredValue;
            } while(error > 3.0f);
            // return to initial thrust once pitch is corrected
            dataBuf[0] = initialThrust;
        }
    }
}
```

3.3.5 Movement

Movement for the sub will be accomplished by programming the thrusters through the Arduino MEGA. The distributeThrust routine can be seen below.

```
void distributeThrust()
{
    std::stringstream leftFront, leftSide, rightSide, rightBack,
    rightFront, leftBack;

    std::string data;

    leftFront << (int)(dataBuf[0] * 0.01 * PWM_MAX_BRIDGED);
    leftSide << (int)(dataBuf[1] * 0.01 * PWM_MAX);
    rightSide << (int)(dataBuf[2] * 0.01 * PWM_MAX);
    rightBack << (int)(dataBuf[3] * 0.01 * PWM_MAX_BRIDGED);
    rightFront << (int)(dataBuf[4] * 0.01 * PWM_MAX);
    leftBack << (int)(dataBuf[5] * 0.01 * PWM_MAX);
}
```

```

data = leftFront.str() + "," + leftSide.str() + "," +
rightSide.str() + "," + rightBack.str() + "," +
rightFront.str() + "," + leftBack.str();

myArduinoMega << data;

leftFront.str("");
leftSide.str("");
rightSide.str("");
rightBack.str("");
rightFront.str("");
leftBack.str("");
}

```

Thus the dataBuf array is how the sub's movements are programmed. For a sense of scale, a value of 35 in dataBuf[1] and dataBuf[2] is enough to move the sub forward through the

	Location of Thrusters and State					
Type of Movement	Front Left	Front Right	Back Left	Back Right	Left Side	Right Side
Forwards	Off	Off	Off	Off	Positive - On	Positive - On
Reverse	Off	Off	Off	Off	Negative - On	Negative - On
Rotate Left	Off	Off	Off	Off	Off	Positive - On
Rotate Right	Off	Off	Off	Off	Positive - On	Off
Ascend	Positive - On	Positive - On	Positive - On	Positive - On	Off	Off
Descend	Negative - On	Negative - On	Negative - On	Negative - On	Off	Off

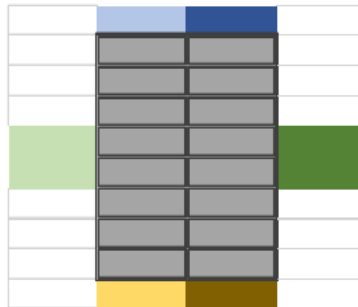

qualification gate. The mapping of thruster settings to movement is shown below.

Figure 13: Thruster Mapping and Placement

Source: <https://www.researchgate.net/publication/321111111>

Thus, by manipulating the dataBuf array the RoboSub can be made to move in various ways. It is important to note that the thruster orientation has moved several times, as a definitively optimal arrangement has yet to be determined. This orientation was selected for now based on previous year's work. However, an orientation where two thrusters are on the bottom, perpendicular to the front of the sub, is in consideration as it would allow better rotational movement and potential y-direction control. The current orientation is still of primary interest due to the sub's need to have thrusters push it down just to negate the inherent buoyancy.

4. Test Plan

4.1 System and Integration Test Plan

4.1.1 Power Systems

Scheduled Test Reporting Form

Test Item: Power Systems Test

Tester Name: Bjorn Campbell

Tester ID No: bec12

Test Date: January 8th 2015

Test No: 01

Test Time: 5 pm - 7 pm

Test Type: Hardware

Test Location: COE

Test Result: Pass

Test Objective:

Fully functional power distribution design from previous year.

Test Description/Requirements:

Requirements:

- 1) Powered Zotac
- 2) Motor controllers
- 3) Arduino mega
- 4) Arduino uno
- 5) Depth sensor
- 6) IMU unit at required voltages and currents

Process:

Test the lithium ion batteries, universal laptop battery, and alternative batteries for voltage and current specifications. The lithium ion batteries should be chargeable. They should output 14.8 volts can have a current of 3.5 amps. The lithium ion batteries have to be connected to the controls of the motor controllers. The motor controllers need provide different voltages to the thrusters. For the universal laptop battery a voltage of 19V is required, with a current of 1.5 amps. The Zotac is connect to the universal laptop battery. The Zotac has the arduino's, and IMU are connected. The arduino uno and arduino mega receive 7 volts from the Zotac. The IMU receives 5 volts from the Zotac. The alternative battery needs to supply 14 volts. The alternative battery is connected to the depth sensor. The depth sensor needs 8-28 volts, and will draw a current of 5 milliamps. After the correct values from the batteries are obtained the batteries need to be tested for battery life. The batteries need to last longer than 30 minutes.

Anticipated Results:

Lithium ion batteries power the motor controllers. The universal battery powers the zotac. The zotac powers the arduino mega, arduino uno, and IMU. The alternative battery powers the depth sensor

Requirement for Success:

Lithium ion batteries, universal battery, and alternative battery, all power their desired system. Also all the batteries need to be able to be rechargeable.

Actual Results:

Lithium ion batteries output desired 14.8 volts. The lithium ion batteries powers the motor controllers, and thrusters. The universal laptop battery supplies 19 volts. The universal laptop battery has connection problems. The output cable is damaged and need to be replaced. The alternative battery provides 14 volts. The alternative battery powers the depth sensor.

Reason for Failure:

The previous design team stated the universal laptop batteries connection problem. The failure is because the battery was dropped.

Recommended Fix:

Buying a new universal laptop battery is required to fix the problem.

Other Comments:

The universal laptop battery was replaced and no current power systems exist.

4.1.2 Depth Control

Scheduled Test Reporting Form

Test Item: Ascend and Submerge Sub Using Thrusters

Tester Name: Elliot Mudrick

Tester ID No: emm10k

Test Date: Mid-February

Test No: 07

Test Time: TBD

Test Type: Hardware Integration

Test Location: Morcom Aquatic Center

Test Result: TBD

Test Objective:

Ensure that the sub can submerge and ascend in the pool.

Test Description/Requirements:**Requirements:**

- 1) Team Members (2+)
- 2) RoboSub
- 3) Pool
- 4) External computer
- 5) 100ft ethernet cable

Process:

Run a test program that turns on the thrusters to submerge the sub to a specific depth. Make changes to thruster strength and weight distribution as necessary until sub can submerge effectively. Repeat process for ascension.

Anticipated Results:

The sub will probably struggle to submerge and ascend evenly due to the sub's buoyancy and uneven weight distribution.

Requirement for Success:

The sub should be able to submerge and ascend to predetermined depths.

Actual Results:

TBD

Reason for Failure:

N/A

Recommended Fix:

N/A

Other Comments:

N/A

Scheduled Test Reporting Form

Test Item: Maintain Depth

Tester Name: Elliot Mudrick

Tester ID No: emm10k

Test Date: Mid-February

Test No: 06

Test Time: TBD

Test Type: Hardware integration

Test Location: Morcom Aquatic Center

Test Result: TBD

Test Objective:

The sub should be able to maintain it's depth under the water.

Test Description/Requirements:**Requirements:**

- 1) Team Members (2+)
- 2) Sub
- 3) Pool
- 4) External computer

5) 100 ft Ethernet debugging cable

Process:

Submerge to an arbitrary depth and adjust thrusters until the depth can be maintained. Repeat test for various other depths.

Anticipated Results:

The sub will probably be in perpetual motion. The team will need to work with some error room above and below the depth in question.

Requirement for Success:

The sub needs to be able to maintain specific depths within 6" above or below.

Actual Results:

TBD

Reason for Failure:

N/A

Recommended Fix:

N/A

Other Comments:

N/A

4.1.3 Obstacle Recognition and Movement

Scheduled Test Reporting Form

Test Item: Underwater Object Recognition

Tester Name: Dennis Boyd

Tester ID No: dcb11c

Test Date: TBD

Test No: 05

Test Time: TBD

Test Type: Hardware/Software

Test Location: Morcom

Test Result: TBD

Test Objective:

This test will determine proper functionality of the two cameras, while submerged. The cameras are intended to identify objects by color and draw their shape, identifying the center (or other values) for calculations (the data is stored in the database). Specifically, the front camera needs to be able to identify the Gate, and the bottom camera needs to recognize the Path.

Test Description/Requirements:

Requirements:

- 1) The sub (with both cameras)
- 2) Two or more team members
- 3) External computer connected via Ethernet
- 4) Objects to detect
- 5) The pool

Process:

Place objects in the pool to observe. Attach the Ethernet cable to the external laptop and verify functionality. Begin running the ColorDetection program. Place the sub in the pool, and face the front camera towards the first object (the thrusters are not needed for this test, the diver will simply manipulate the sub's position manually). Confirm on the external laptop that the object has been identified by the camera. Confirm that the correct values have been updated in the database. Then, place the second object in front of the bottom camera. Confirm on the external laptop that the object has been identified by the bottom camera and that the correct values have been updated in the database. If these both succeed, place objects in front of both cameras and verify that the results of each individual camera have not changed.

Anticipated Results:

The cameras will be able to simultaneously locate objects. However, the water distortion may cause this to fail, or to be imprecise. The RGB values the camera searches will probably need to be adjusted for underwater colors.

Requirement for Success:

The objects are identified by both cameras and the correct values are updated to the database.

Actual Results:

TBD

Reason for Failure:

N/A

Recommended Fix:

N/A

Note: If it does fail, likely the RGB values or filters need to be adjusted.

Other Comments:

The cameras are working excellently out-of-water. The main worry which needs testing is that the water will distort the image, causing the objects to no longer be recognized. RGB values may need to be coordinated to ensure colors underwater are what they need to be. Filtering should help fix this too.

Scheduled Test Reporting Form

Test Item: Gate Traversal

Tester Name: Kevin Matungwa

Tester ID No: krm12d
Test Date: Mid-February
Test No: 08
Test Time: TBD
Test Type: Test
Test Location: Morcom Aquatic Center
Test Result: TBD

Test Objective: The Objective of this test to verify that the sub can successfully navigate through the gate

Test Description/Requirements:

Requirements:

- 1) Orange Gate
- 2) Pool
- 3) Team Members (2+)
- 4) External computer

Process

The test will kick off by placing the 6ft tall 10ft tall gate in the pool and aligning the sub with the gate. The external Laptop will be used to run the both the vision executable and the Robosub_Control_v2. The sub will submerge to operating depth and once properly aligned with the center of the gate, it will begin moving towards.

Anticipated Results:

Once the forward camera detects that the gate distance has reached the minimum threshold the sub will continue to drift through the gate and trigger that task completion

Requirement for Success:

The sub needs complete the task of going through the gate in a straight line multiple times producing similar results

Actual Results:

TBD

Reason for Failure:

N/A

Recommended Fix:

N/A

Other Comments:

N/A

Scheduled Test Reporting Form

Test Item: Line Following

Tester Name: Kevin Matungwa
Tester ID No: krm12d
Test Date: Early to Mid-March
Test No: 09
Test Time: TBD
Test Type: Hardware/Software Integration
Test Location: Morcom Aquatic Center
Test Result: TBD

Test Objective:

Ensure that the sub can effectively follow lines under water. The sub will be approximately three feet above the line and should stay within 2 feet to the right or the left of the line.

Test Description/Requirements:

Requirements:

- 1) Team Members (2+)
- 2) RoboSub
- 3) Pool
- 4) External computer
- 5) Debugging ethernet cable
- 6) Orange path
- 7) Ability to maintain depth

Process:

First ensure that the sub can identify the line. Next utilize the front facing camera to close in on the line. Once the bottom camera detects the line, the sub will align itself parallel to the line and maintain depth. Finally the sub will engage forward thrusters and traverse the line while maintaining alignment and depth.

Anticipated Results:

The camera may struggle to identify the line object in deep water. In the process of alignment, the sub may continue to drift due to the lag of thruster response which could throw off the alignment

Requirement for Success:

The sub will position itself approximately 3 feet above the line, follow the line until it ends and maintain alignment during the process.

Actual Results:

TBD

Reason for Failure:

N/A

Recommended Fix:

N/A

Other Comments:

N/A

4.1.4 Overall Movement/Path**Scheduled Test Reporting Form****Test Item:** Gate and Path Combined Traversal**Tester Name:** Dennis Boyd**Tester ID No:** dcb11c**Test Date:** TBD**Test No:** 11**Test Time:** TBD**Test Type:** Final Test**Test Location:** Morcom Aquatic Center**Test Result:** TBD**Test Objective:**

This test will determine if the sub can move from one task to another. The sub should be able to complete the Gate task, and upon completion, begin following the Path.

Test Description/Requirements:**Requirements:**

- 1) RoboSub
- 2) Team Members (2+)
- 3) Orange Gate
- 4) Orange Path
- 5) External computer attached with ethernet cable

Process:

Place the Gate in the pool, with the Path after it. With the RoboSub beginning facing the Gate, run the control program and let it do its thing.

Anticipated Results:

The sub will pass through the Gate successfully. It will then begin looking for the Path. Hopefully it will find the Path and align itself with it. Depending on the depth of the sub after going through the Gate, it may have difficulty finding the Path on the bottom camera. In this case, the front camera must be used, which will likely be imprecise. Furthermore, the sub is likely to have difficulty lining up with the Path on early tests.

Requirement for Success:

The sub successfully traverses the Gate and then aligns itself with the Path and follows it.

Actual Results:

TBD

Reason for Failure:

N/A

Recommended Fix:

N/A

Other Comments:

This will be the first step towards completing tasks for points in the competition.

4.2 Test Plan for Major Components

4.2.1 Sub Hull

Scheduled Test Reporting Form**Test Item:** Waterproofing**Tester Name:** Samantha Cherbonneau**Tester ID No:** src11k**Test Date:** 2/3/15**Test No:** 03**Test Time:** 10 am – 12 pm**Test Type:** Test**Test Location:** Morcom Aquatic Center**Test Result:** Pass**Test Objective:**

The objective of this test is to ensure that the sub is completely waterproof at all operating depths currently available.

Test Description/Requirements:**Requirements:**

1. RoboSub hull
2. Team members (2+)
3. Weights
4. Rope/cord (17+ ft)

Process:

All electronics will be removed from the sub hull so there is no chance of damage to the electronics. An additional 30lb weights will be added to the sub to make it easier to submerge in the pool and ropes will be wrapped around the hull to lower the sub into the water. A rope will be tied length and width wise around the sub. Then another long rope will be tied around those 2 ropes. This is to attempt to keep the sub from tipping during the process. The sub will be slowly lowered to the bottom of the pool and then slowly pulled back up with a team member in the water for safety. The seals around the sub will be thoroughly inspected to determine if any water passed through.

Anticipated Results:

The sub will be fully waterproof at the bottom of the pool and all depths in between.

Requirement for Success:

No water passed through any of the seals in the sub.

Actual Results:

The students first used 2 30lb weights but it was way more weight than what was required for the sub to sink. One 30lb weight was removed and the sub was lowered to the bottom. The sub was reeled back in with the rope and had no leaks whatsoever.

Reason for Failure:

N/A

Recommended Fix:

N/A

Other Comments:

The seal should be checked regularly. The plexiglass cracks should also be documented and checked regularly.

4.2.2 Depth Sensor

Scheduled Test Reporting Form

Test Item: Initial Depth Sensor Test

Tester Name: Bjorn Campbell

Tester ID No: bec12

Test Date: January 17th 2015

Test No: 02

Test Time: 2 pm

Test Type: Hardware

Test Location: Morcom Aquatics Center

Test Result: Pass

Test Objective:

Find the maximum voltage outputted by the new depth sensor, and that the cable is waterproof.

Test Description/Requirements:**Requirements:**

Produces a voltage output what follows a linear correlation to submerged depths. No air bubble are detected coming out of the cable line.

Process:

Depth sensors cables are soldered and waterproofed to the Seacon male connector. 14 foot green cable wire is connected to the 2 foot Seacon connector. The depth sensors black cable will be connected to a voltage source supplying 10 volts. The depth sensors white cable will be connected to ground of the voltage source and the multimeter. The depth sensors red cable will be connected to the multimeter. The depth sensor will then be lowered into the pool at different lengths.

Anticipated Results:

That the depth sensor gives a different voltage at different depths.

Requirement for Success:

The depth sensor gives different voltages at different depths, with the varying of the voltage relating linearly to the depth submerged.

Actual Results:

The below graph and table show the results obtained. The sensor was only submerged to a depth of 14 feet. The sensor was not placed at the maximum depth of the pool length of cable was 14 feet. The depth sensor should never reach the bottom of the pool. The bottom camera will hit the bottom first. The sub needs to be at least three feet off the bottom of the pool. A depth of 14 feet in a 17 feet pool is the idea depth. The voltage output follows a linear correlation.

Table 3: Depth Sensor Initialization Results

Depth Sensor Initialization Check	
Depth that Sensor is submerged [ft]	Voltage
0 (atmospheric pressure)	0.66 mV
0.5	110 mV
2.5	0.4 V
4	0.56 V
14	1.90 V

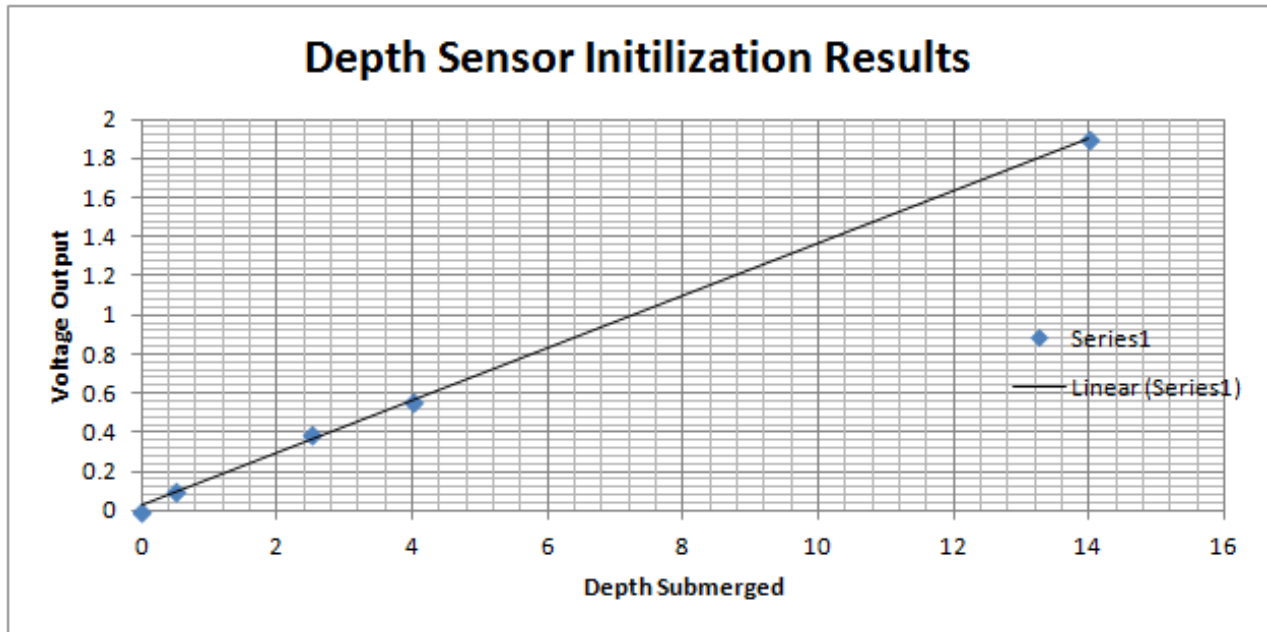
**Reason for Failure:**

N/A

Recommended Fix:

N/A

Other Comments:

The depth sensor initialization test was a success. The maximum voltage for a 17 foot pool should be 2 volts. Possible problem to consider: The depth sensor is sensitive to atmospheric pressure. The variation should be minimal but should be noted each day. The maximum voltage for the competition pool is unknown. The cables have to stay waterproof, and should always be checked for cracks.

4.2.3 Obstacles**Scheduled Test Reporting Form****Test Item:** Gate Construction**Tester Name:** Samantha Cherbonneau**Tester ID No:** src11k**Test Date:** 2/3/14**Test No:** 04**Test Time:** TBD**Test Type:** 10 am – 12 pm**Test Location:** Morcom Aquatic Center**Test Result:** Pass

Test Objective:

The objective of this test is to ensure that the gate is adequately constructed and will not come apart in the pool, will not move about in the pool once inserted, and will not sink to the bottom of the pool.

Test Description/Requirements:**Requirements:**

1. Gate components (2 orange side pipes, 2 top pipes)
2. Pool
3. Team members (2+)

Process:

First tie a rope to each of the 4 pieces to prevent them from sinking to the bottom of the pool and secure the ropes on the surface. The side pipes will be inserted into the water to fill with water. Next, the top pipes will be connected to the side pipes, while still containing a proper air-water ratio to ensure that an adequate buoyancy is maintained. This ratio will be adjusted as necessary to determine what works best to keep the gate in place in the pool.

Anticipated Results:

The gate will float towards the top of the water, with the side pipes perpendicular to the water's surface. The gate will remain immobile in the pool unless intentionally moved.

Requirement for Success:

The gate floats in the proper orientation to allow the sub to pass through it.

Actual Results:

The gate floated first try for 30 minutes without sinking. It was a great success.

Reason for Failure:

N/A

Recommended Fix:

N/A

Other Comments

N/A

4.2.4 Killswitch

Scheduled Test Reporting Form

Test Item: Killswitch

Tester Name: Dennis Boyd

Tester ID No: dcb11c

Test Date: TBD

Test No: 10

Test Time: TBD

Test Type: Hardware

Test Location: Senior Design Lab/Morcom

Test Result: TBD

Test Objective:

This is a simple test to ensure that the killswitch is functioning properly. When the killswitch is toggled, the sub should stop. This should also function underwater.

Test Description/Requirements:

Requirements:

- 1) The sub (with affixed killswitch)
- 2) Two or more team members
- 3) External computer connected via ethernet
- 4) The pool

Process:

First test the killswitch above water to ensure functionality. Begin running the sub in the pool. Have a diver toggle the killswitch. Observe whether or not the sub halts.

Anticipated Results:

Upon flipping the switch, the sub turns off. Specifically, all thrusters need to stop completely.

Requirement for Success:

The sub turns off.

Actual Results:

TBD

Reason for Failure:

N/A

Recommended Fix:

N/A

Other Comments:

N/A

4.3 Summary of Test Plan Status

Table 4: Status of All Tests Past and Upcoming

Test	Status
Power Systems	Pass
Ascend and Submerge Sub Using Thrusters	TBD
Maintain Depth	TBD
Underwater Object Recognition	TBD
Gate Traversal	TBD
Line Following	TBD
Gate and Path Combined Traversal	TBD
Waterproofing	Pass
Initial Depth Sensor Test	Pass
Gate Construction	Pass
Killswitch	TBD

5. Schedule

Below is the schedule for the remainder of the year, along with the tasks already completed. The tasks colored in red have been completed.

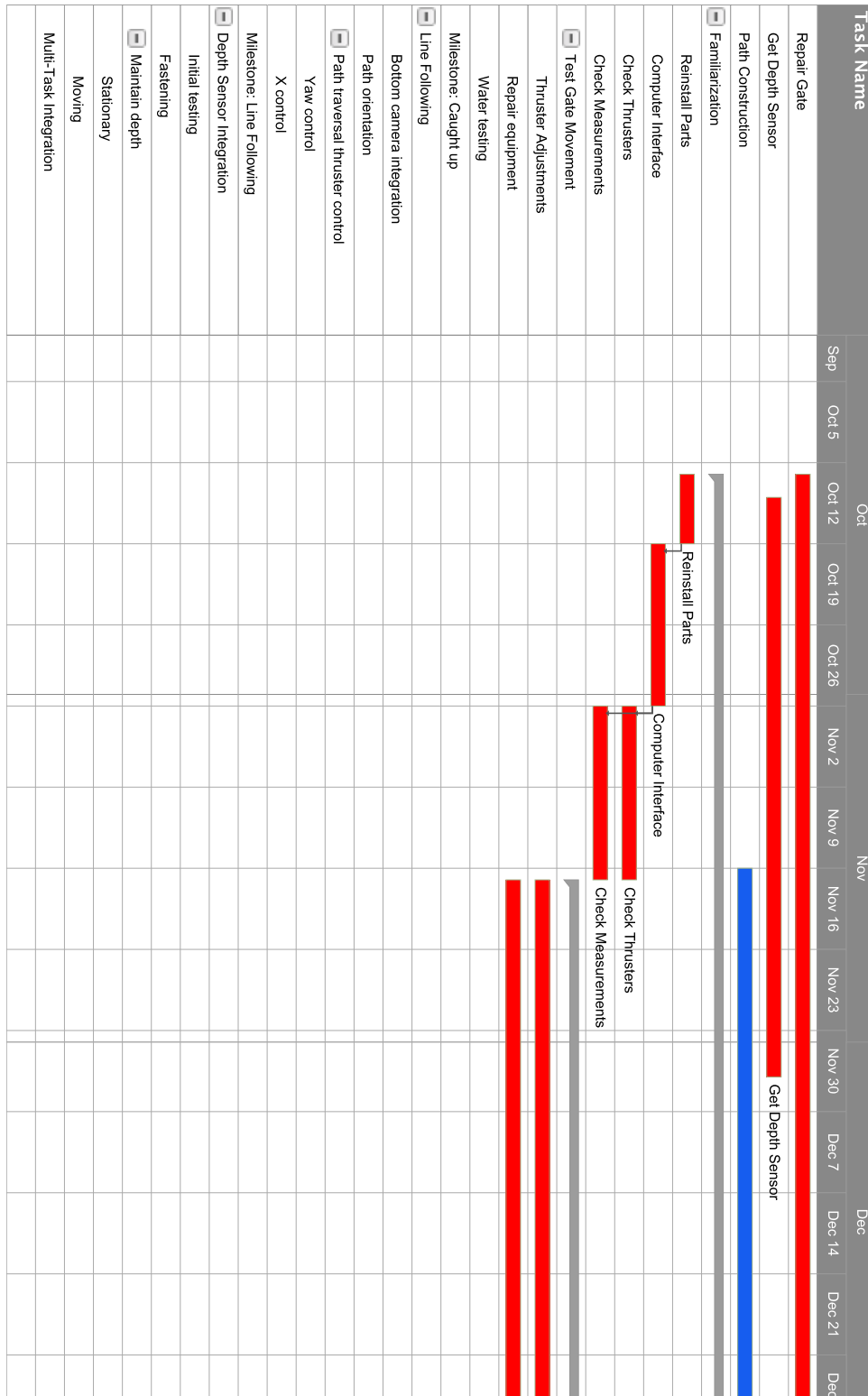

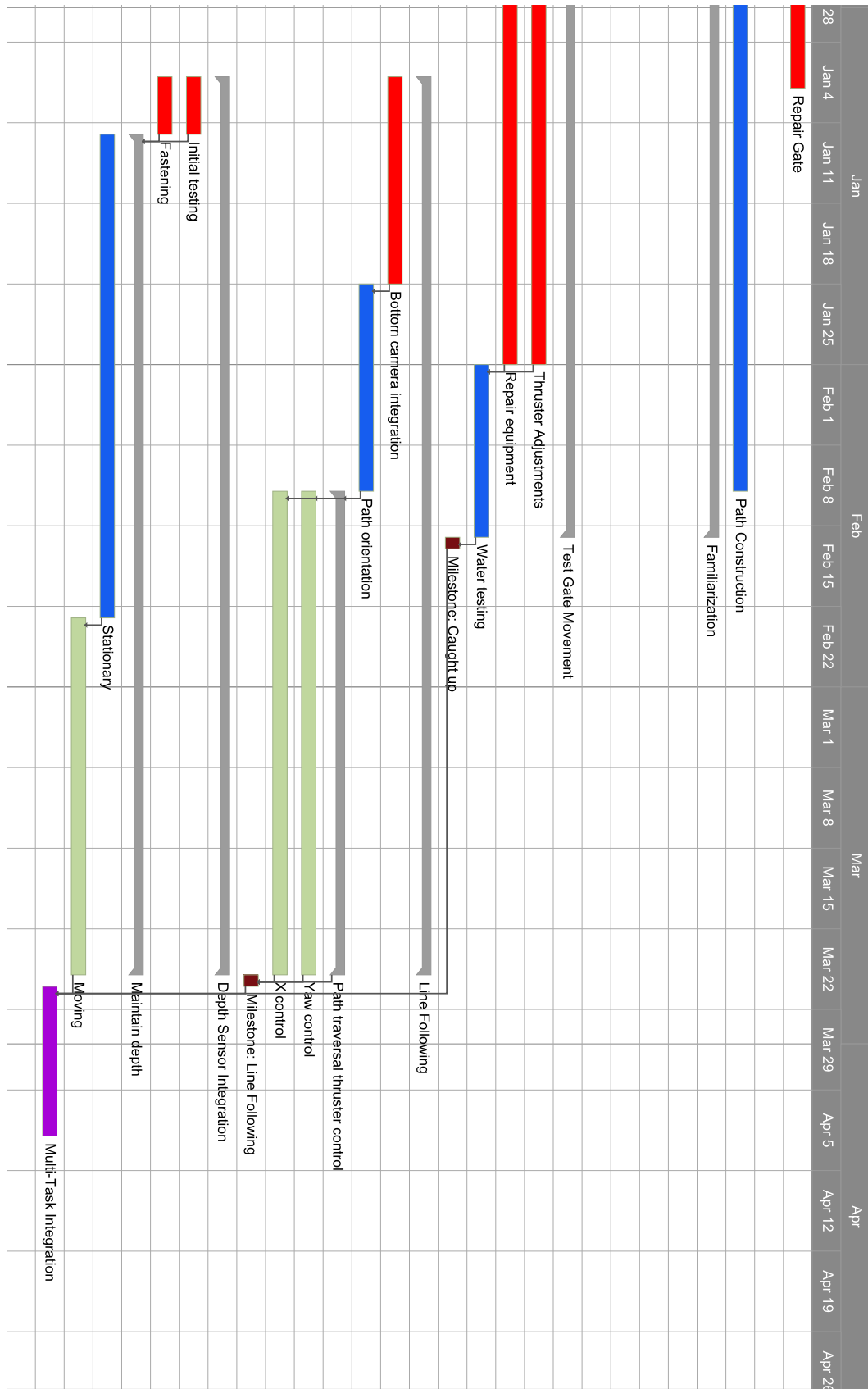

6. Budget Estimate

Table 5: Estimated Personnel Budget

A. Personnel	Total Hours	Hourly Wage	Total Pay
Dennis Boyd	360	\$30.00	\$10,800.00
Samantha Cherbonneau	360	\$30.00	\$10,800.00
Bjorn Campbell	360	\$30.00	\$10,800.00
Kevin Matungwa	360	\$30.00	\$10,800.00
Elliot Mudrick	360	\$30.00	\$10,800.00
		Wage Subtotal	\$54,000.00
B. Fringe Benefits			\$15,660.00
C. Total Personnel Cost			\$69,660.00

Table 6: Estimated Expense Budget

D. Expense	Purpose	Vender	Qty	Price	Total
3" Diameter x 10' Long PVC	Center Horizontal PVC Pipe, Vertical PVC Pipes for Gate	Home Depot	2	\$14.98	\$29.96
90 Degree Elbows 3" PVC	Connectors for the Gate	Home Depot	2	\$2.57	\$5.14
2" Clean Out Tee PVC	Connect center PVC of Gate	Home Depot	1	\$1.37	\$1.37
Blaze Orange Duck Tape	Vertical color of vertical PVC pipes	Home Depot	2	\$3.37	\$6.74
Heat Gun	Heat Shrink Tubing	Harbor Freight	1	\$14.99	\$14.99
Heat Shrink Tubing Assorted Sized	Waterproofing outside connection cables	Harbor Freight	1	\$4.99	\$4.99
Liquid Electrical Tape	Waterproofing outside connection cables	West Marine	1	\$10.99	\$10.99
Heat Shrink Tubing Large Size	Waterproofing outside connection cables	West Marine	1	\$16.99	\$16.99
Push Button Switch	Kill Switch	Chrome Glow	1	\$6.49	\$6.49
Hex Keys 10pc	Required to move thrusters	Home Depot	1	\$5.35	\$5.35
Cable Tie	Multiple uses including attaching components, and equipment	Home Depot	1	\$6.96	\$6.96
Zotac Wall Charger	Increase battery life	Amazon	1	\$11.63	\$11.63
1"x6" – 8 FT Weather Shield Wood	Path Lines	Home Depot	2	\$5.37	\$10.74
Hallow Braid Poly Rope (1/4" x50')	Needed for mooring lines	Home Depot	1	\$5.60	\$5.60

2" Diameter by 6' Long PVC	Maneuvering parts, Horizontal and Vertical	Home Depot	2	\$8.22	\$16.44
90 Degree Elbows 2" PVC	Connectors for the Maneuvering Platform	Home Depot	2	\$0.83	\$1.66
2" Clean Out Tee PVC	Connect center PVC of Maneuvering Platform	Home Depot	1	\$3.26	\$3.26
PVC Glue	Need to seal maneuvering structure to become buoyant	Home Depot	1	\$4.87	\$4.87
2" PVC Caps	Seal vertical	Home	2	\$1.64	\$3.28
16/19 V Ah LI-Ion Universal External Battery	Old Battery damaged, battery life is limited	AA Portable Power Corp	1	\$74.76	\$74.76
Depth Sensor+Shipping	Required for sub		1	\$354.00	\$371.24
Current Budget Spent					\$577.83
Total Expected Budget	Maneuvering Structure+Path			\$45.85	\$623.68
Allotted Budget					\$750.00
Competition Entry Fee	Necessary to compete		1	\$500.00	\$500.00
Plane tickets	Necessary to compete	TBD	3	\$250.00	\$750.00
Sub Transportation	Necessary to compete	TBD	1	\$150.00	\$150.00
Car Rental	Necessary to compete	TBD	6	\$75.00	\$450.00
				Expenses Subtotal (including tax)	\$2,600.00
E. Total Direct Costs (C+D)					\$72,260.00
F. Overhead Costs (45% of E)					\$32,517.00
G. Total OCO (E+F)					\$104,777.00

7. Conclusion

The team has largely familiarized themselves with the components and software that was provided from previous teams. After the new depth sensor and replacement battery have arrived and been installed, testing will begin to verify that the existing code is still functional. The team is familiarized with the previous implementations, and is working on getting the sub to move through the gate underwater and following the orange line on the bottom of the pool. The team intends to repurpose previously implemented code such as color recognition and the vision code for use with these new tasks in addition to implementing new functions and improving upon old functions. The team is on track in regards to scheduling and the schedule will continue to act as a guideline for the process. The budget shown in Section 6 is up to date and reflects all recent purchases with accurate prices. At this time, it does not appear that the team will go over budget. Many tests have been created to test all parts of the sub that will contribute to a successful traversal of the course obstacles we have set out to complete. Testing has begun and is on schedule to finish on time.

8. References

- [1] *Autonomous RoboSub 2013-14 Final Report*. Autonomous RoboSub, 2014, PDF.
- [2] *RoboSub_Project_Proposal_2012*. FSU RoboSub, 2012, PDF.
- [3] *Autonomous RoboSub 2013 Detailed Design Review*, Autonomous RoboSub, 2013, PDF.
- [4] *Levelgag General Purpose Level Transmitter*. Keller America Inc., Accessed 2014, PDF.
- [5] *Operations/Maintenance Manual*. Autonomous RoboSub, 2014, PDF.